

mira

Aquations

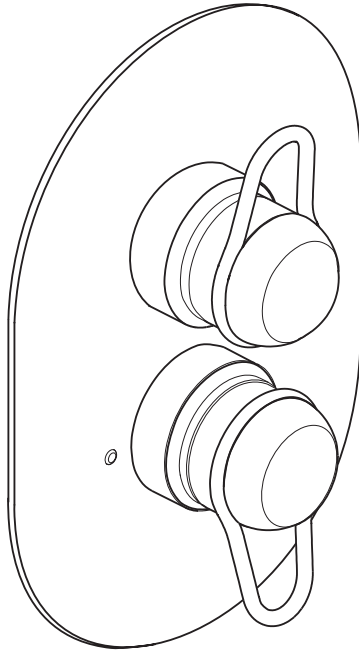

MIRA AQUATIONS

SHOWER CONTROL

Installation & User Guide

These instructions are to be left with the user

CONTENTS

Introduction	3
Safety : Warnings	3
Pack Contents	4
Dimensions	5
Specification	6
Normal Operating Conditions	6
Operating Parameters	6
Connections	7
Installation Requirements	8
Installation	11
General	11
Reversed Inlet Supplies	12
Installation: Solid and dry-lined walls	13
Installation: Panels (4 to 19 mm thickness) Rear Mounted	15
Installation: Panels (>6 mm thickness) Front Mounted	16
Commissioning	17
Operation	20
Fault Diagnosis	21
Maintenance	23
General	23
Maintenance Procedures	24
Lubricant	24
Maintenance Procedure - Thermostatic Cartridge	25
Maintenance Procedure- Flow Cartridge	27
Maintenance Procedure - Checkvalve Cartridges	28
Maintenance Procedure - Inlet Strainers	29
Removing/Fitting Lever and Concealing Plate Assemblies	30
Spare Parts	32
Notes	34
Customer Service	Back Page

INTRODUCTION

The Mira Aquations Thermostatic mixing valve is specified to meet the highest standards of safety, comfort and economy as demanded by today's users. The Mira Aquations is designed, manufactured and supported in accordance with accredited BS EN ISO 9001:1994 Quality Systems.

This Manual covers all Mira Aquations Thermostatic mixing valves manufactured from April 2003.

The Mira Aquations Shower Valve is a thermostatic shower control with independent selection for temperature and spray force and is suitable for connection to concealed pipework.

Mira Aquations Built-in, with 15 mm compression inlet/outlet connections. Supplied hot-left, cold-right but can be reversed.

SAFETY : WARNINGS

This Aquations Thermostatic Shower Control is precision engineered and should give continued safe and controlled performance, provided:

1. It is installed, commissioned, operated and maintained in accordance with manufacturers recommendations.
2. Periodic attention is given, when necessary, to maintain the product in good functional order.

The function of a thermostatic mixing valve is to deliver water consistently at a safe temperature. In keeping with every other mechanism, it cannot be considered as functionally infallible and as such, cannot totally replace a supervisor's vigilance where that is necessary. Provided it is installed, commissioned, operated and maintained within manufacturers recommendations, the risk of failure, if not eliminated, is reduced to the minimum achievable.

If you experience any difficulty with the installation or operation of your new shower control, then please refer to '**Fault Diagnosis**', before contacting Kohler Mira Limited. Our telephone and fax numbers can be found on the back cover of this guide.

PACK CONTENTS

Tick the appropriate boxes to familiarize yourself with the part names and to confirm that the parts are included.

1 x Valve Body

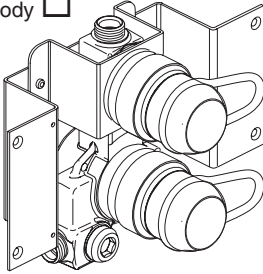

3 x Compression Nuts



3 x Olives



1 x Foam Seal

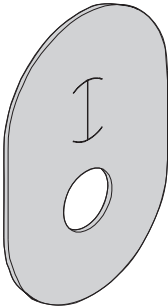

1 x Outer Seal

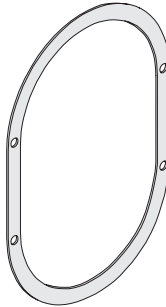

1 x Building-in Shroud

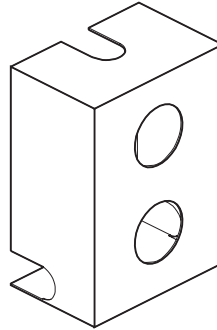

1 x Concealing Plate

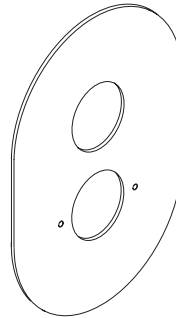

4 x Wall Plugs

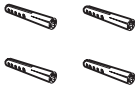

4 x Countersunk Fixing Screws

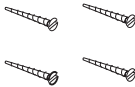

4 x Countersunk Short Bolts

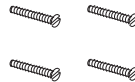

1 x Hexagonal Key



Documentation

1 x Installation, Operation and Maintenance Guide

1 x Customer Support Brochure

DIMENSIONS

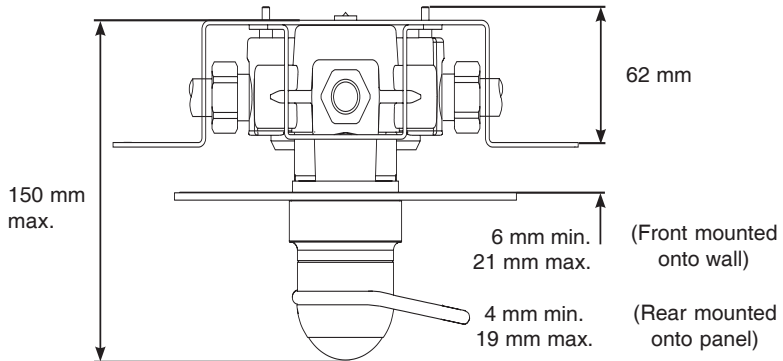
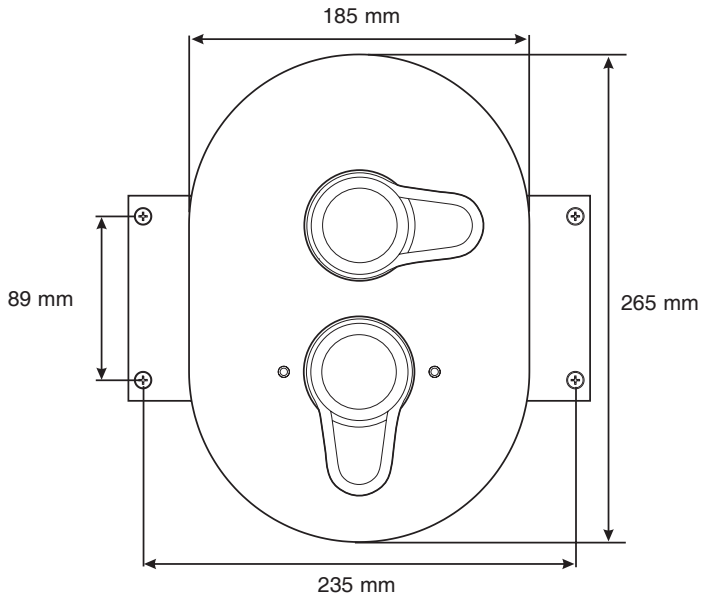

SPECIFICATION

Normal Operating Conditions:

Normal operating conditions are considered as:

- inlet dynamic pressures nominally balanced to within 10% of each other during flow.
- a differential of approximately 50°C between the hot and cold inlet temperatures, and with differentials of 15-35°C between the blend setting and either supply.
- daily usage of 1-6 hours.
- installation and usage environment not subject to extremes of temperature, unauthorised tampering or wilful abuse.

Other Applications

For information on other specific applications or suitability, refer to Kohler Mira Ltd, or Local Agent.

Operating Parameters

Pressures and Flow Rates

For optimum performance, dynamic supply pressures should be nominally equal.

Recommended Minimum Dynamic Supply Pressure: 0.15 bar.

Recommended Minimum Flow Rate: 8 l/min at mid-blend with equal dynamic supply pressures.

Recommended Maximum Flow Rate: 35 l/min at mid-blend (which equates to maximum pressure loss of 3.2 bar).

Maximum Pressure Loss Ratio*: should not exceed **10:1**, in favour of either supply, during flow.

Maximum Static Pressure is 10 bar.

Recommended maximum flow velocity in pipelines is 2 metres/second.

**Pressure Loss Ratio is determined by subtracting the resistance to flow at the outlet (generally known as "back pressure", and measured at the outlet of the mixing valve) from the maintained pressures of the hot and cold water at each inlet of the mixing tap. This is at its extreme when the mixing valve is being used at its lowest flow rate and when the maximum inequality occurs in the pressure of the hot and cold water supplies.*

Mira Aquations (Mixing Valve only)

Flow Rate/Pressure Loss Graph

(Maintained supply pressures are equal and outlet temperature set to mid-blend)

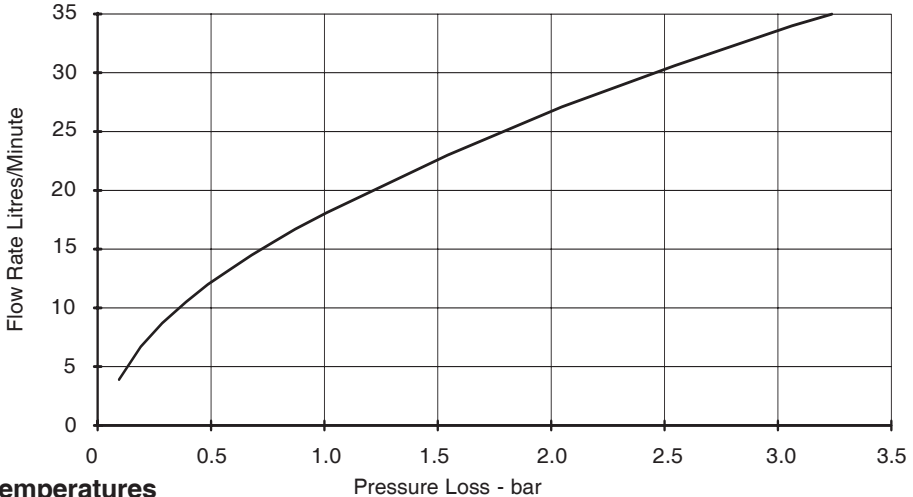

Temperatures

Optimum performance is obtained when **temperature differentials** of **20°C** or more exist between blend and either supply. Blend control accuracy will begin to diminish at temperature differentials below **12°C**.

Blend Temperature Range: Between ambient cold and approximately 60°C, according to hot water supply temperature.

Thermostatic Control Range: Approximately 25-60°C.

Optimum Thermostatic Control Range: 30-50°C.

Recommended Minimum Cold Water Supply Temperature: 1°C.

Recommended Maximum Hot Water Supply Temperature: 85°C.

Note! The shower control can accept temporary temperature excursions above 85°C without damage, however operation at such elevated supply temperatures is not recommended. For reasons of general safety, hot water storage temperatures should ideally be maintained at between 60-65°C where serving ablutionary applications. Minimum temperature differential between hot and outlet temperature: **10°C.**

Note! The operating parameters above are for the valve only. The operating parameters for the outlet fittings should also be taken into consideration when installing this product.

Connections

The shower control connections are all 15 mm compression (nuts and olives are provided).

Hot (H) and Cold (C) inlets are clearly marked for the shower control and **must** be connected as described in the **Installation** section.

INSTALLATION REQUIREMENTS

Key to Symbols

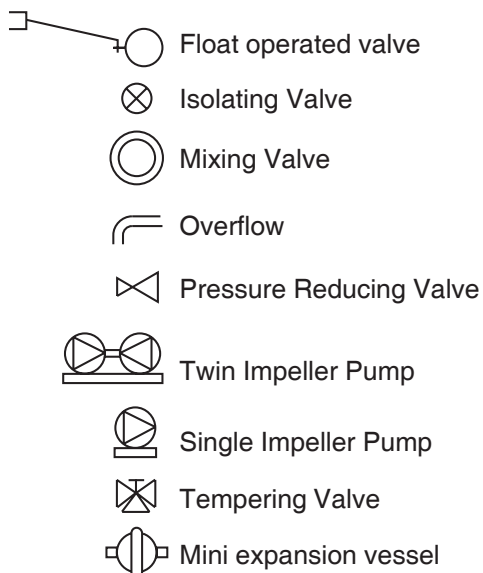

Gravity Fed Shower - The shower **MUST** be fed from a cold water cistern and hot water cylinder providing nominally equal pressure.

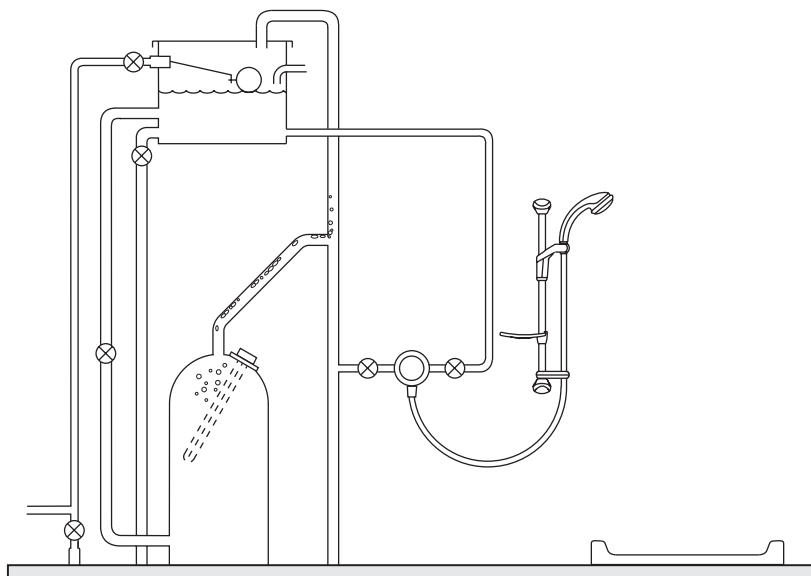

Gas Heated Shower - The shower **MUST** be installed with a gas water heater or combination boiler of a **fully modulating** design. A modulating boiler is one that the draw off rate is indirectly controlling the gas flow to the boiler, producing a relatively constant hot water temperature.

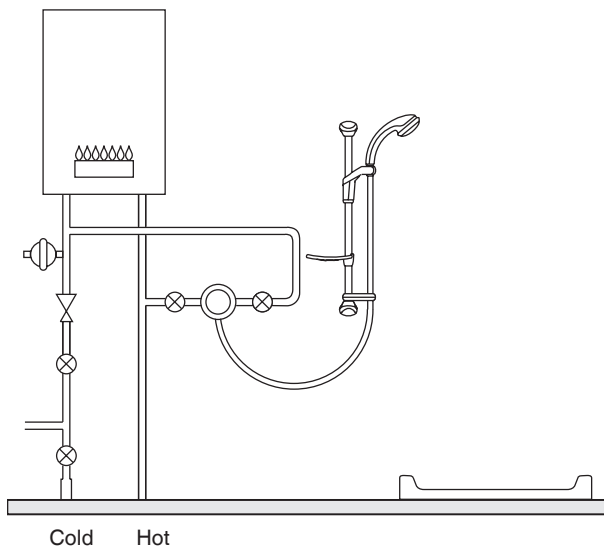

Unvented Mains Pressure Shower - The shower can be installed with a unvented, stored hot water cylinder. Only “a competent person” as defined by the Building Regulations may fit this type of system.

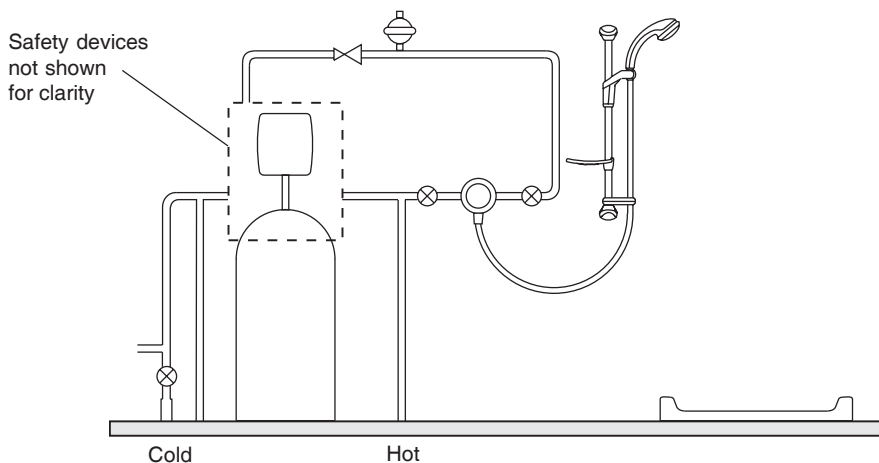

Mains Pressurised Instantaneous Hot Water Shower - The shower installed with systems of this type is supplied hot water via a tempering valve, this provides relatively constant hot water and the shower will compensate for temperature changes should they occur.

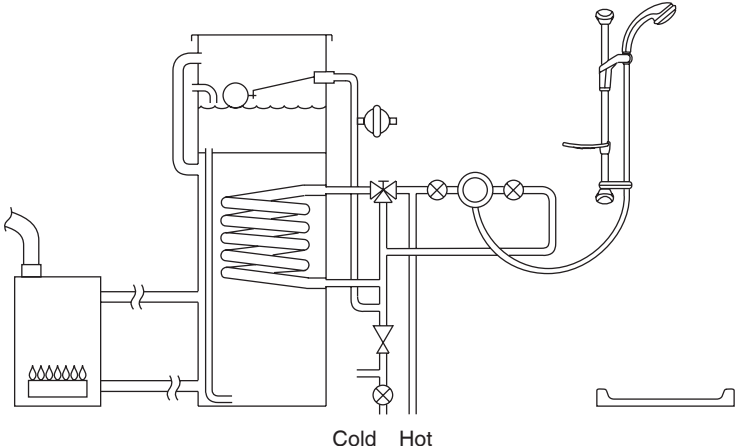

Pumped Shower - The shower can be installed with an inlet pump (twin impeller). The pump must be installed on the floor next to the hot water cylinder. Ensure hot cylinder vent pipe is arranged as shown to enable air separation.

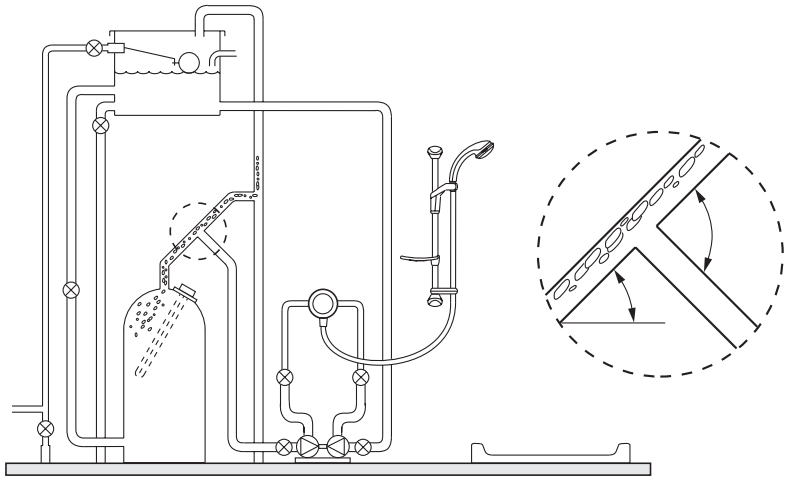

INSTALLATION

General

Installation must be carried out in accordance with these instructions, and must be conducted by designated, qualified and competent personnel.

The installation must comply with the “Water Supply Regulations 1999 (Water Fittings)” or any particular regulations and practices, specified by the local water company or water undertakers.

1. Before commencing, make sure that the installation conditions comply with the information given in **SPECIFICATION**.
2. Care must be taken during installation to prevent any risk of injury or damage.
3. The mixing valve should be positioned for easy access during use and maintenance. All routine maintenance procedures can be conducted with the mixing valve body in place (except for strainer and checkvalve access). For all models, allow a minimum 80 mm clearance in front of the temperature control to enable removal of the serviceable parts during maintenance.
4. The use of supply-line or zone strainers will reduce the need to remove debris at each mixing valve point. The recommended maximum mesh aperture dimension for such strainers is 0.5 mm.
5. Pipework should be rigidly supported.
6. Pipework dead-legs should be kept to a minimum. The mixed water outlet piping should not exceed 2 m and the overall length from the hot water circuit to the discharge point should not exceed 5 m.
7. Supply pipework layout should be arranged to minimise the effect of other outlet usage upon the maintained pressures at the mixing valve inlets.
8. Inlet and outlet threaded joint connections should be made with PTFE tape or liquid sealant. Oil-based, non-setting jointing compounds should not be used.
9. To eliminate pipe debris it is essential that supply pipes are thoroughly flushed through before connection to the mixing valve.

The Mira Aquations shower control can be built into solid, dry-lined, stud partition or dry partition wall structures. All plumbing connections are 15 mm compression.

A building-in shroud is supplied, which can provide a depth reference when chasing out the wall surface and also protects the shower control during plastering.

Reversed Inlet Supplies

It is essential the inlet supplies correspond with the red and blue markings on the thermostatic cartridge fitted in the Mira Aquations in order to operate correctly. The shower control is supplied with the inlet connections configured **hot-left, cold-right**. If the existing hot and cold pipework make this configuration inconvenient the cartridge inlets can be reversed.

The connections can be altered by rotating the thermostatic cartridge through 180°, before or after installation.

1. If the mixing valve body has already been installed, isolate the supplies to the mixing valve, and turn on the flow control. This will release the pressure and assist in draining the residual water.
2. Remove the knob and cover assemblies. Refer to **Removing/Fitting Knob and Cover Assemblies** for detailed instructions.
3. With the removal clip still in place, unscrew the head nut using a 35 mm A/F wrench; this will begin to draw the thermostatic cartridge out of the body.

Note! Some residual water may be released. Pull the thermostatic cartridge free of the valve body.

4. Rotate the thermostatic cartridge through 180° and carefully push the cartridge back into the valve body, checking that the 2 cartridge inlet port seals remain in place, and locate cartridge lugs into the body slots.

Note! The red and blue markings on the cartridge will now not correspond with the body markings, so to avoid future confusion remove the red and blue stickers from the valve body.

5. Carefully align and then tighten the head nut; **do not overtighten**.
6. Complete the **INSTALLATION**, if appropriate.
7. If the mixing valve body has already been installed, restore hot and cold supplies and check for any leaks.
8. Refit the foam seal, concealing plate and secure in position with the locknuts. Ensure the foam seal remains in position as the locknuts are screwed back into position. Refit the locknut trims and lever assemblies. (Refer to **Removing/Fitting Lever and Concealing Plate Assemblies**).
9. The maximum temperature may now need resetting; check, and if necessary refer to **COMMISSIONING**.

Installation: Solid and dry-lined walls

1. Decide on a suitable position for the shower control and shower fittings. Ideally the shower outlet should be fitted facing down the centre-line of the bath or across the opening of the shower cubicle, at a convenient height for all the family.
2. Determine whether the hot or cold water services will be connected to the shower control from the top (falling) or from the bottom (rising).
3. Familiarise yourself with the hot and cold water inlet and outlet ports.
4. Determine the route for the outlet pipework. For further information on installing the shower fittings refer to the relevant Fittings Installation, Operation and Maintenance Guide.
5. Mark the route of the inlet and outlet pipework and the approximate shape of the recess (185 mm high x 155 mm wide).
6. Remove the plaster and brickwork/dry-lining to the required depth using the building-in shroud as a reference. The wall mounting bracket requires a minimum building-in depth of 60 mm.

The total building-in depth for the shower control (to the finished wall surface) can be between 66 mm and 81 mm. This will accommodate a final thickness of plaster and tiles of between 6 mm and 21 mm.

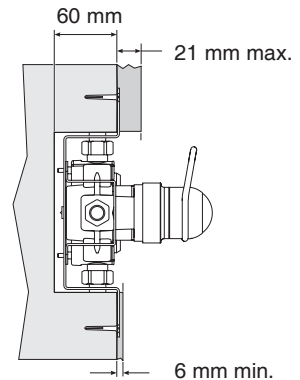
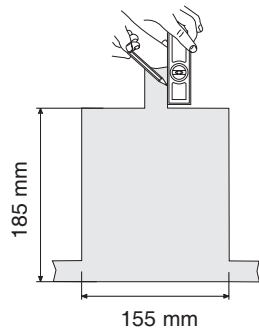
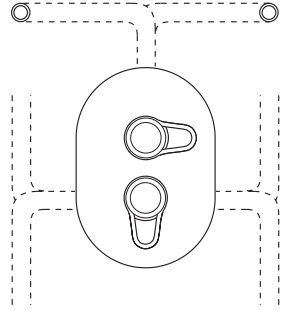

7. Mark the position of the wall mounting bracket fixing holes. Drill a 6.0 mm diameter hole at each of the marked positions and insert the wall plugs (supplied).

8. Install the hot and cold supply pipes.

9. **Flush the hot and cold water supply pipes thoroughly. The supplies must be clean and free from debris before connecting the shower control. Failure to do so may result in product malfunction.**

10. Mount the shower control in the recess and connect the inlet pipework. Check the hot and cold supplies have been connected to the correct inlets. If necessary the valve inlets can be reversed, refer to **REVERSED INLET SUPPLIES** for further information.

Note! If the wall screws cannot be fixed into the wall, fit the building-in shroud and fill the cavity behind the mounting bracket with an appropriate material (e.g. expandible foam).

11. Install the outlet pipework and connect to the shower control. Check for leaks and inlet and outlet connections are watertight.

12. Remove the lever controls and locknuts (Refer to **Removing/Fitting Lever and Concealing Plate Assemblies**) and fit the building-in shroud over the valve in the recess. Plaster and tile, or finish as appropriate, up to edge of the shroud. **The final wall surface must fall between the 2 lines on the building-in shroud.**

13. When the wall surface has been completed, remove the building-in shroud.

14. Fit the concealing plate seals and concealing plate to the valve. The main seal needs to be fitted with the smooth side facing the wall. This will help ensure an effective seal.

Note! Should the wall surface or tiling be uneven, the seal will need to be assisted/substituted with silicone sealant.

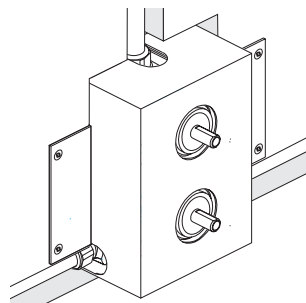
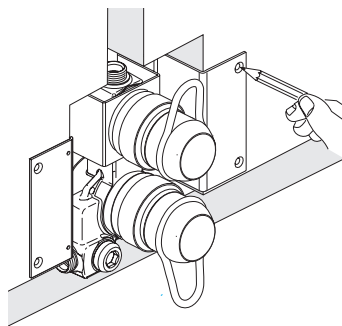

Installation: Panels (4 to 19 mm thickness) Rear Mounted

The Mira Aquations incorporates a mounting bracket, enabling the valve to be installed through a laminated panel or shower cubicle.

The bracket must be in the correct orientation and mounted to the rear face of panels of 4-19 mm finished thickness.

1. Put the building-in shroud in the correct position on the wall and draw around it with a pencil. Cut out the hole in the panel.
2. Using the valve and the building-in shroud as a template, mark and drill 4 fixing holes to secure the mounting bracket in position. If no further finishing surface is to be added use the four inner fixing holes to mount the valve, in order to conceal the fixing screws when the concealing plate is fitted.
3. Follow the instructions outlined in **Installation: solid and dry lined walls.**
4. If access is available it may be preferable to make the initial valve/pipework connections prior to securing the mixing valve to the panel.
5. Mount the mixing valve securely onto the rear of panel, with the panel fixing screws (supplied).
6. **Important! Flush through the hot and cold supplies thoroughly before connection to mixing valve.**
7. Connect inlet and outlet pipework, checking that the hot and cold supplies have been piped to the correct inlets. Check for water leaks and all connections are watertight.
8. Follow previous instructions for **wall recess installation.** Refer to **COMMISSIONING** before operating the shower control.

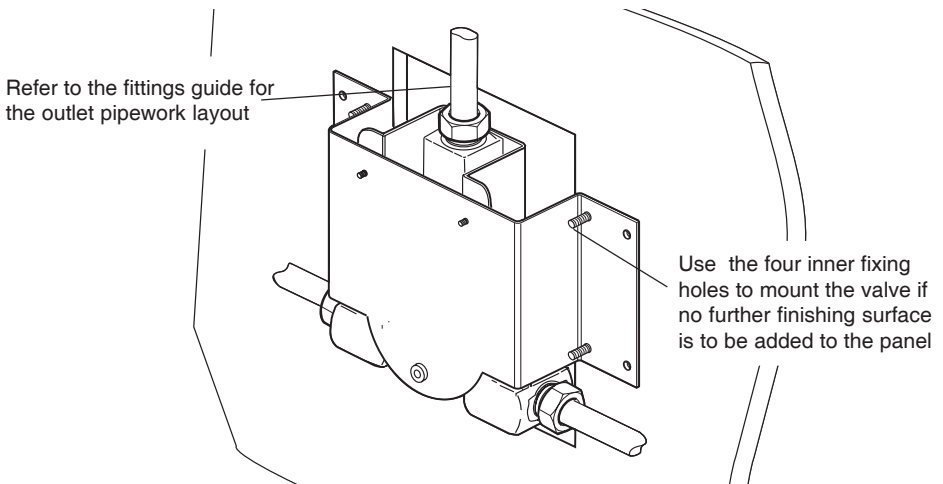

Installation - panel (4 to 19 mm thickness)

Installation: Panels (>6 mm thickness) Front Mounted

Note! The mounting bracket can also be mounted to the front face of panels thicker than 6 mm provided the thickness of any further finishing layer is between 6 mm and 21 mm. The mounting bracket needs to be correctly orientated for this building method.

1. Cut a hole 185 mm high x 155 mm wide in the panel.
2. Using the valve and support bracket as a template, mark and drill 4 fixing holes to secure the mounting bracket in position. The fixing hole dimensions must be suitable for the selected securing method, and appropriate for the particular panel material.
3. Follow the instructions outlined in **Installation: solid and dry lined walls**.
Note! The inlets accept rising or falling supplies, on thicker panels this may require the inlet pipework to be configured with elbows or pipe bends immediately prior to the inlet connections.
4. Plaster and tile, or finish as appropriate, up to the panel hole perimeter only, and to a maximum thickness of 21 mm over the front face of the mounting bracket. Protect the mixing valve and pipe connections during this process.
5. Follow the instructions outlined in **Installation: solid and dry lined walls**. Refer to **COMMISSIONING** before operating the shower.

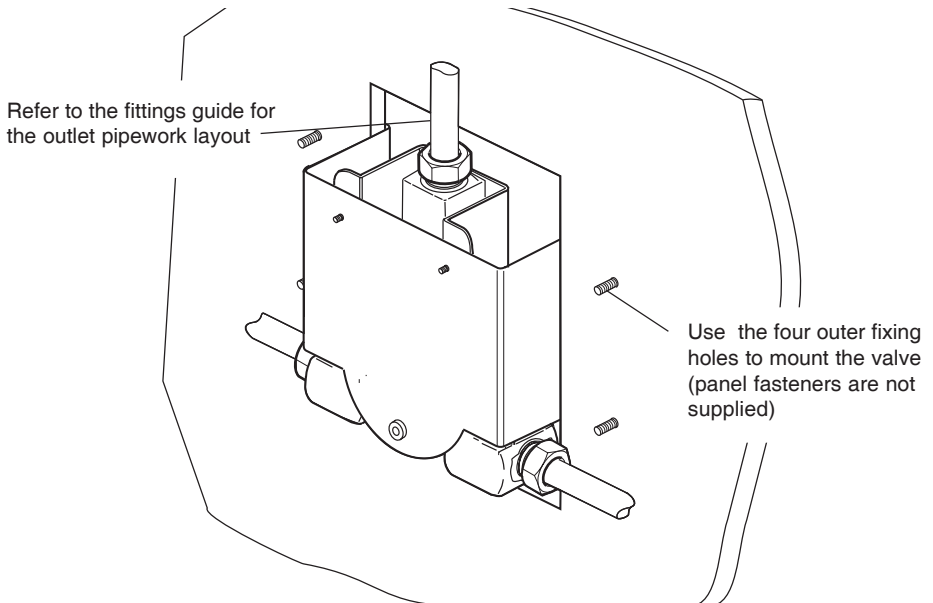

Installation - panel (>6 mm thickness)

COMMISSIONING

Commissioning must be carried out in accordance with these instructions, and must be conducted by designated, qualified and competent personnel.

Exercising the Thermostat

Thermostatic mixing valves with wax thermostats are inclined to lose their responsiveness if not used. Valves which have been in storage, installed but not commissioned, or simply not used for some time should be exercised before setting the maximum temperature or carrying out any tests.

A simple way to provide this exercise is:

- (a) make sure that the hot and cold water are available at the valve inlets, and the outlet is open.
- (b) move the temperature control rapidly from cold to hot and hot back to cold several times, pausing at each extreme.

Maximum Temperature

The maximum blend temperature obtainable by the user should be limited, to prevent accidental selection of a temperature that is too hot.

All Mira Thermostatic mixing valves are fully performance tested and the maximum temperature is preset to approximately 43°C under ideal installation conditions at the factory.

Site conditions and personal preference may dictate that the maximum temperature has to be reset following installation.

This shower control is provided with an adjustable temperature control knob, which allows the user to select the blend temperature between ambient cold up to a preset maximum.

Maximum Temperature Setting

Check that an adequate supply of **hot** water is available at the hot inlet of the shower control.

During resetting, the hot supply to the shower must be as close to the typical maximum to offset the possibility of any blend shift due to fluctuating supply temperatures. However, the minimum temperature of the hot water **must** be at least 12°C above the desired blend for correct thermostatic operation.

Temperatures should always be recorded using a thermometer with proven accuracy. Check that both inlet isolating valves are fully open. Turn the temperature knob to maximum and operate the flow control. Allow the temperature to stabilize and check the outlet temperature.

- If the outlet temperature is set correctly then refer to **Commissioning Checks**.
- If adjustment of the temperature is required, carry out the procedure below:

1. Remove the temperature knob and locknut assemblies.
2. Release the securing screw on the temperature spindle using a 3 mm hexagonal wrench and remove the temperature spindle.
3. Rotate the cartridge spindle until the required maximum blend temperature is obtained at the discharge point (**clockwise = decrease temperature**).
When resistance is felt do not use force to turn any further, as this can damage the internal parts.
4. Refit the temperature spindle at the maximum temperature position and secure with the locking screw.
5. Refit the temperature knob and locknut assemblies.
Note! The locknut will need to be fitted with the threaded end away from the valve to make sure the concealing plate and seals are correctly compressed.
6. Rotate the temperature knob through its full range of movement to make sure that the full range of water temperatures can be selected.

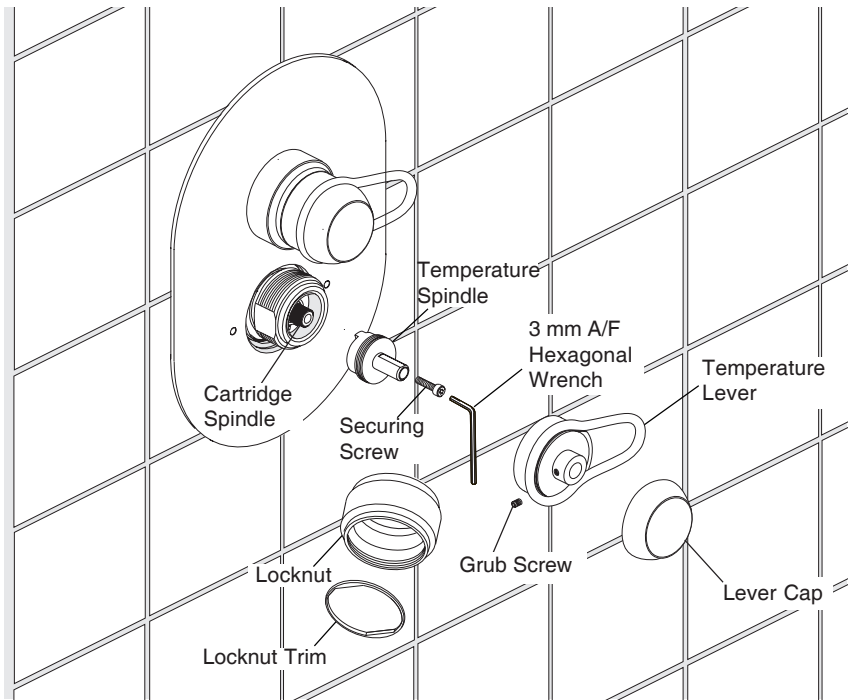

Maximum Temperature Setting

Commissioning Checks

(Temperatures should always be recorded with a thermometer with proven accuracy).

1. Check inlet pipework temperatures for correct function of checkvalves i.e. that hot water does not cross flow into the cold supply and vice versa.
2. Check that the supply pressures are within the operating pressures for the valve.
3. Make sure that all connections and mixer body are water tight.
4. Exercise the thermostat.
 - (a) make sure that the hot and cold water are available at the valve inlets, and the outlet is open.
 - (b) move the temperature control rapidly from cold to hot and hot back to cold several times, pausing at each extreme.
5. Adjust the temperature of the mixed water in accordance with the instructions (refer to **Maximum Temperature Settings**).
6. Operate the outlet flow control and check:
 - (a) Flow rate is sufficient for the purpose.
 - (b) Temperature(s) obtainable are acceptable.

OPERATION

Turn the flow lever anticlockwise until the desired force of water is obtained.

Note! When the Aquations shower control is installed with a fully modulating multipoint or combination type gas water heater, the maintained mains water pressure, and hence the flow, must be sufficient to keep the heater ignited. Therefore, it is important to make sure that the flow knob is fully open to prevent variation in the hot water supply temperature.

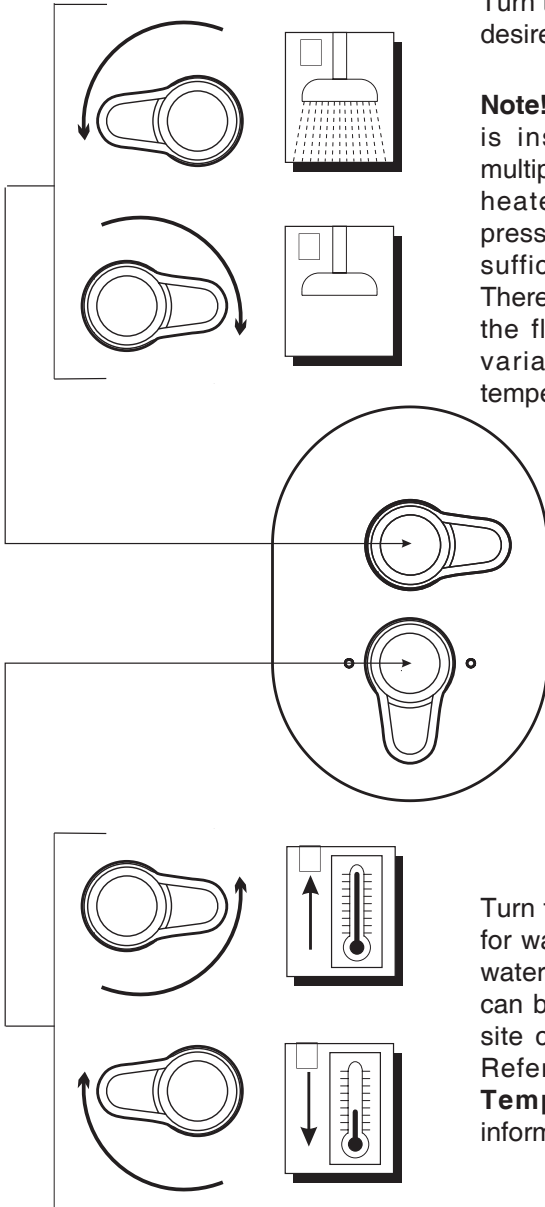

Turn the temperature lever anticlockwise for warmer water or clockwise for cooler water. The preset maximum temperature can be adjusted as required to suit both site conditions and the user's comfort. Refer to **Commissioning, Maximum Temperature Setting** for further information.

FAULT DIAGNOSIS

Symptom	Cause/Rectification
1. Only hot or cold water from outlet.	<ul style="list-style-type: none"> a. Inlet supplies reversed (see reversed inlets section). Check. b. No hot water reaching shower control. Check. c. Check strainers and inlet/outlet fittings for blockage. d. Refer symptom 5 below. e. Installation conditions continuously outside operating parameters: refer to SPECIFICATION, and 2e below.
2. Fluctuating or reduced flow rate.	<p>Normal function of thermostatic control when operating conditions are unsatisfactory:</p> <ul style="list-style-type: none"> a. Check strainers and inlet/outlet fittings for flow restriction. b. Make sure that minimum flow rate is sufficient for supply conditions. c. Make sure that dynamic inlet pressures are nominally balanced and sufficient. d. Make sure that inlet temperature differentials are sufficient. e. (Subsequent to rectification of supply conditions) Check thermostatic performance; renew thermostatic cartridge, if necessary.
3. No flow from shower control outlet.	<ul style="list-style-type: none"> a. Check strainers and inlet/outlet fittings for blockage. b. Hot or cold supply failure; thermostat holding correct shutdown function: rectify, and refer to symptom 2.e. above. c. Flow control cartridge faulty. Check and renew if necessary.
4. Blend temperature drift.	<p>Indicates operating conditions changed.</p> <ul style="list-style-type: none"> a. Refer to symptom 2. above. b. Hot supply temperature fluctuation. c. Supply pressure fluctuation.
5. Hot water in cold supply or vice versa.	<p>Indicates checkvalves require maintenance, refer to MAINTENANCE.</p>
6. Maximum blend temperature setting too hot or too cool.	<ul style="list-style-type: none"> a. Indicates incorrect maximum temperature setting; refer to COMMISSIONING. b. As symptom 4. above. c. As symptom 5. above.

Symptom	Cause/Rectification
7. Water leaking from shower control body.	Seal(s) worn or damaged. a. Obtain service pack and renew all seals. b. (If leak persists from around temperature spindle) Renew thermostatic cartridge.
8. Flow knob or temperature knob stiff to operate.	a. Impaired free movement of internal components. Renew the appropriate cartridge. b. Supply pressures too high. Fit pressure reducing valve. Refer to SPECIFICATIONS for acceptable operating pressures.

MAINTENANCE

General

1. The maintenance of this product must be carried out in accordance with instructions given in this Manual, and must be conducted by designated, qualified and competent personnel.
2. Mira products are precision-engineered and should give continued superior and safe performance, provided:
 - They are installed, commissioned, operated and maintained in accordance with the recommendations stated in this Product Manual.
 - Periodic attention is given as necessary to maintain the product and its associated installation components in good functional order. Guidelines are given below.
3. The use of main supply-line or zone strainers (recommended maximum mesh aperture dimension is 0.5 mm) will reduce the need to remove debris at each mixing valve point.

The designed minimum service life of all cartridges used in Mira products is 5 years providing the Mira Aquations is operated with the recommended operating conditions and within the recommended operating parameters. However, when supply conditions and/or usage patterns do not conform to the recommended operating parameters and/or the recommended operating conditions, the cartridge and other critical parts may need to be replaced more frequently ('recommended operating conditions' and 'recommended parameters' are defined in section: '**Specifications**' under the headings of '**Normal Operating Conditions**' and '**Operating Parameters**').

Maintenance Procedures

Maintenance must be carried out in accordance with these instructions, and must be conducted by designated, qualified and competent personnel.

This mixing valve is designed for minimal maintenance under conditions of normal use.

External surfaces may be wiped clean with a soft cloth, and if necessary, a mild washing-up type detergent or soap solution can be used.

Warning! Many household and industrial cleaning products contain mild abrasives and chemical concentrates, and should not be used on polished, chromed or plastic surfaces.

Should an internal malfunction occur then this will probably require replacement of parts.

Components are precision-made, so care must be taken while servicing to avoid damage.

When ordering spare parts, please state product type, i.e. Mira Aquations, and identify part name and number (refer to **PARTS LIST**). A Seal pack is available, containing all the seals that may be necessary for renewal during maintenance or servicing.

Lubricant

Important! All seals are pre-lubricated. If you need to lubricate the seals, use only a small amount of silicone-only based lubricants on this product. Do not use oil-based or other lubricant types as these may cause rapid deterioration of seals.

Maintenance Procedure - Thermostatic Cartridge

Removal

1. Isolate the supplies to the shower control, and open the flow control to release pressure and to assist the draining of residual water.
2. Remove the lever knobs, locknuts, concealing plate and seals. Do not remove the temperature spindle.
3. With removal clip still in place, unscrew the head nut using a 35 mm A/F wrench. This will release the headnut and also begin to draw the thermostatic cartridge out of the shower control body.
Caution! Some residual water may be released.
4. Note which inlet aligns with the **hot** (marked **H** and coloured **red**) lug on cartridge.
5. Pull the thermostatic cartridge free of the shower control body.

Cleaning/Renewal of Parts

6. The interior surface of the shower control body must be clean before refitting the cartridge. If scale or deposition is present, clean (**without thermostatic, flow and checkvalve cartridges fitted**) using a mild proprietary inhibited scale solvent, e.g. domestic kettle descaler. After descaling, rinse body thoroughly in clean water before refitting cartridges.
Note! The body interior must be cleaned carefully and not damaged in any way. Do not use any abrasive material.
7. Cartridges may only be cleaned by flushing through under a jet of clean water to remove lodged particles. **Do not descale. Cartridges are not serviceable, and must not be dismantled.**
Cartridges cannot be tested individually, service condition should be assessed as part of the performance check; refer to **Commissioning Checks**.
8. When renewing the thermostatic cartridge, retain the temperature spindle, removal clip and head nut off the displaced unit so they can be fitted to the new cartridge.
9. Examine all accessible seals for signs of deformation or damage, and if necessary renew, taking care not to damage seal grooves (a Service Pack is available, containing all seals and strainer screens that may be necessary for renewal during maintenance or servicing).
10. Lightly coat all rubber seals with a **silicone-only based lubricant** to assist reassembly (see **lubricants**).

Reassembly

11. Identify which is the hot inlet to the shower control body, and align the thermostatic cartridge accordingly. Carefully push the thermostatic cartridge back into the body, checking that the 2 cartridge inlet port seals remain in place, and locate cartridge lugs into body slots.
12. Carefully align and then tighten the head nut; **do not overtighten** (max. Torque 2.5 Nm (1.85 lbf ft)). Fit the removal clip to the head nut.
13. Refit the plate and lever assemblies; Refer to **Removing/Fitting Lever and Concealing Plate Assemblies** for detailed instructions.
14. Turn off the flow control and restore hot and cold supplies and check for any leaks.
15. The maximum temperature will now need resetting; refer to **COMMISSIONING**.

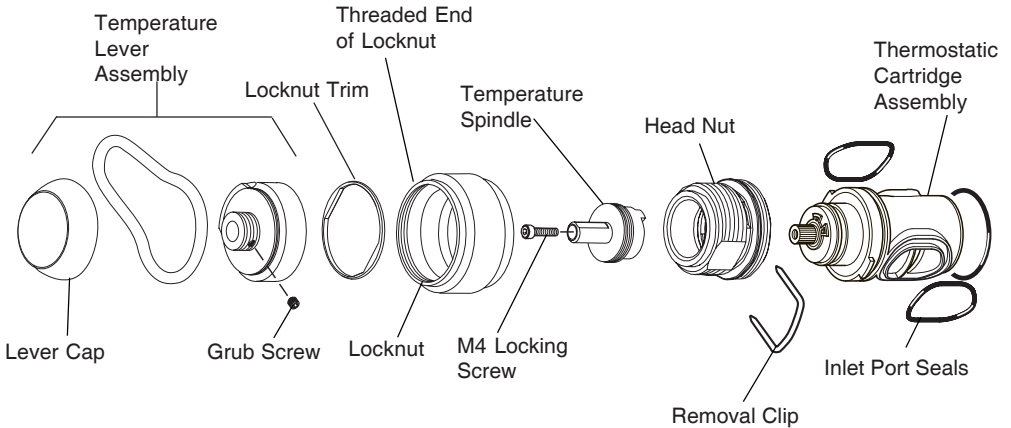

Thermostatic Cartridge Removal

Maintenance Procedure- Flow Cartridge

Removal

1. Isolate the supplies to the shower control, and open the flow control to release the pressure and assist draining the residual water.
2. Remove the lever knob and concealing plate assemblies; Refer to **Removing/Fitting Lever and Concealing Plate Assemblies** for detailed instructions.
3. Remove the splined adaptor.
4. Unscrew the flow cartridge anticlockwise and remove.

Caution! Some residual water may be released.

Cleaning/Renewal of Parts

5. The inner surface of the shower control body must be clean before refitting cartridge. If scale or deposition is present, clean (**without thermostatic, flow and checkvalve cartridges fitted**) using a mild proprietary inhibited scale solvent, e.g. domestic kettle descaler. After descaling, rinse body thoroughly in clean water before refitting the cartridge.

Note! The shower control body must be cleaned carefully and not damaged in any way. **Do not use any abrasive material.**

6. Clean the cartridge by flushing through under a jet of clean water to remove lodged particles. **Do not descale. Cartridges are not serviceable, and must not be dismantled.**

Cartridges cannot be tested individually, service condition should be assessed as part of the performance check; refer to **Commissioning Checks**.

7. Examine accessible 'O' seals for signs of deformation or damage, and if necessary renew the cartridge.
8. Lightly coat all seals with a **silicone-only based lubricant** to assist reassembling.

Reassembly

9. Check that flow cartridge seals are in place. Align and screw the cartridge into place.
10. Fit the splined adaptor.
11. Refit the lever knob and concealing plate assemblies; Refer to **Removing/Fitting Lever and Concealing Plate Assemblies** for detailed instructions.
12. Restore hot and cold supplies and check for leaks.

Maintenance Procedure - Checkvalve Cartridges

Hot water entering the cold supply, or vice versa, indicates the checkvalve cartridge needs immediate attention.

1. Isolate the supplies to the shower control, and open the flow control to release the pressure and assist draining the residual water.
2. Remove the lever knob and concealing plate assemblies; Refer to **Removing/Fitting Lever and Concealing Plate Assemblies** for detailed instructions.
3. Undo the cartridge head using a 12 mm A/F wrench and pull the whole cartridge free from the valve body.

Caution! Some water may be released at this point.

4. The Checkvalve cartridge assemblies may be cleaned by removing the rubber retainers and inlet strainers, and flushing through under a jet of water to remove lodged particles. **Do not descale.** Check if the checkvalve cartridge operates correctly. If the cartridge is damaged or fails to operate correctly renew.
5. Lightly wipe external seals and threads with a **silicone-only based lubricant** to aid refitting.
6. Fit the cartridges and reassemble the shower control following the steps outlined in **Removing/Fitting Lever and Concealing Plate Assemblies**. **Do not overtighten** the cartridge heads when refitting.
7. Restore the water supplies and check for leaks.

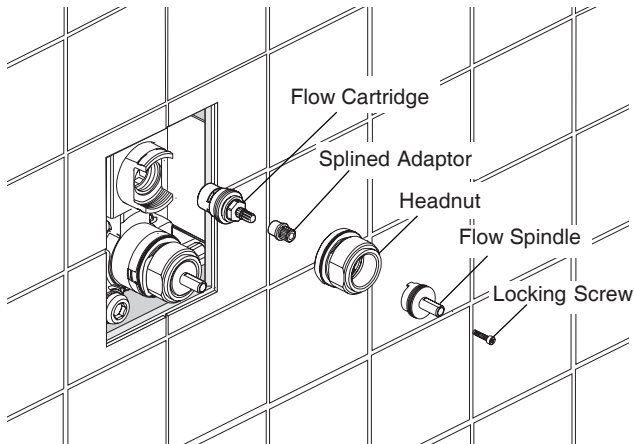

Flow Cartridge Removal

Maintenance Procedure - Inlet Strainers

Blockage of the inlet strainer screens can lead to poor flow performance and reduced temperature control. It is essential that the inlet strainer screens are periodically cleaned or, if necessary, renewed as part of a preventative maintenance programme. A Strainer pack is available for the Mira Aquations, containing 2 strainer screens and 2 retainers.

1. Isolate the supplies to the shower control, and open the flow control to release the pressure and assist draining the residual water.
2. The strainers are located at the inlet of each Checkvalve cartridge. Remove the cartridges to allow access.
3. Carefully remove the strainers. The strainers are dished outwards to minimise their effect on flow performance and maximise debris protection. If damaged performance and protection may be adversely affected.
4. Clean under a jet of water, or renew if damaged.
5. Refit cartridges, strainers and retainers and reassemble the shower control following the steps outlined in **Removing/Fitting Lever and Concealing Plate Assemblies**. **Do not overtighten** the cartridge heads when refitting.
6. Restore the water supplies, and check for leaks.

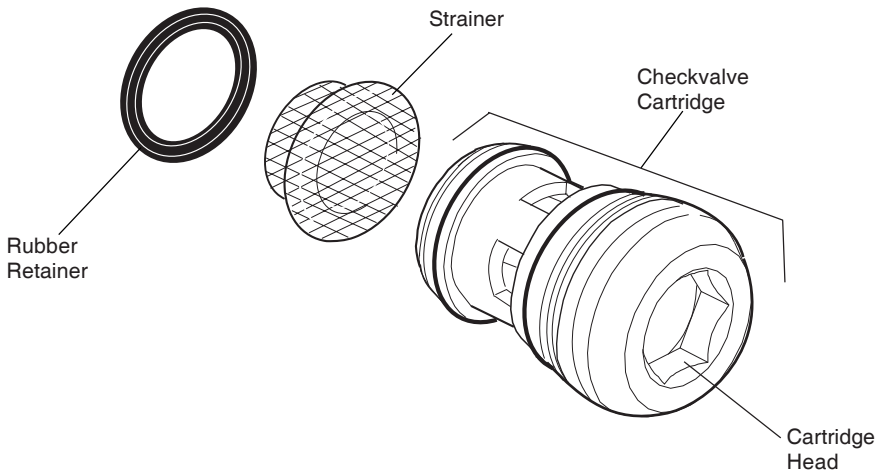
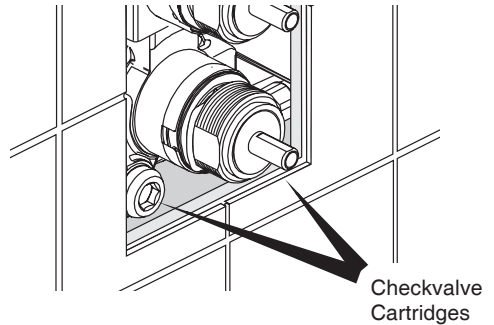

Checkvalve Cartridges

Removing/Fitting Lever and Concealing Plate Assemblies

Removal

1. Rotate the lever knob either fully clockwise or anticlockwise.
2. Unscrew the lever knob cap. Using a 2.5 mm hexagonal key unscrew the grub screw to release lever knob.
3. Remove the control knob and shroud trim.
4. Unscrew and remove the two locknuts which hold the concealing plate in position.
5. Remove the concealing plate and seals to allow access to the valve and recess.

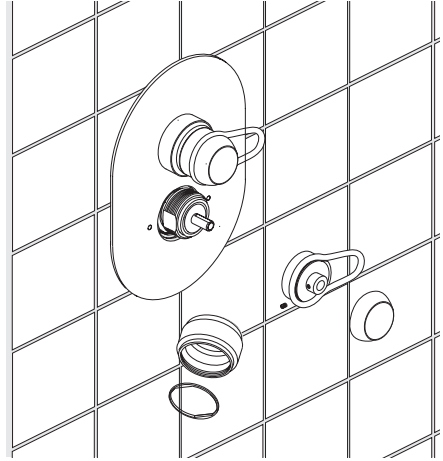

Reassembly

1. Fit the main seal onto the valve. The seal needs to be fitted with the smooth side facing the wall to ensure an effective seal.
Note! Should the wall surface or tiling be uneven, this seal will not be fully effective and should be assisted/substituted by silicone sealant.
2. Fit the outer seal to the concealing plate and push the concealing plate onto the valve. Make sure that neither seal becomes displaced.
3. Whilst holding the concealing plate in position screw the locknuts onto the valve until they firmly lock the concealing plate against the wall. This will compress the concealing plate seals and prevent water ingress into the recess.
Note! The locknut will need to be fitted with the threaded end away from the valve to make sure that the concealing plate and seals are correctly compressed.
4. Refit the locknut trim and lever knobs.
Note! The lever knobs will need to be fitted in the positions they were in before the lever assemblies were removed. The levers may become fouled against each other if incorrectly fitted.
5. Check the knobs can be rotated through the full range of movement.

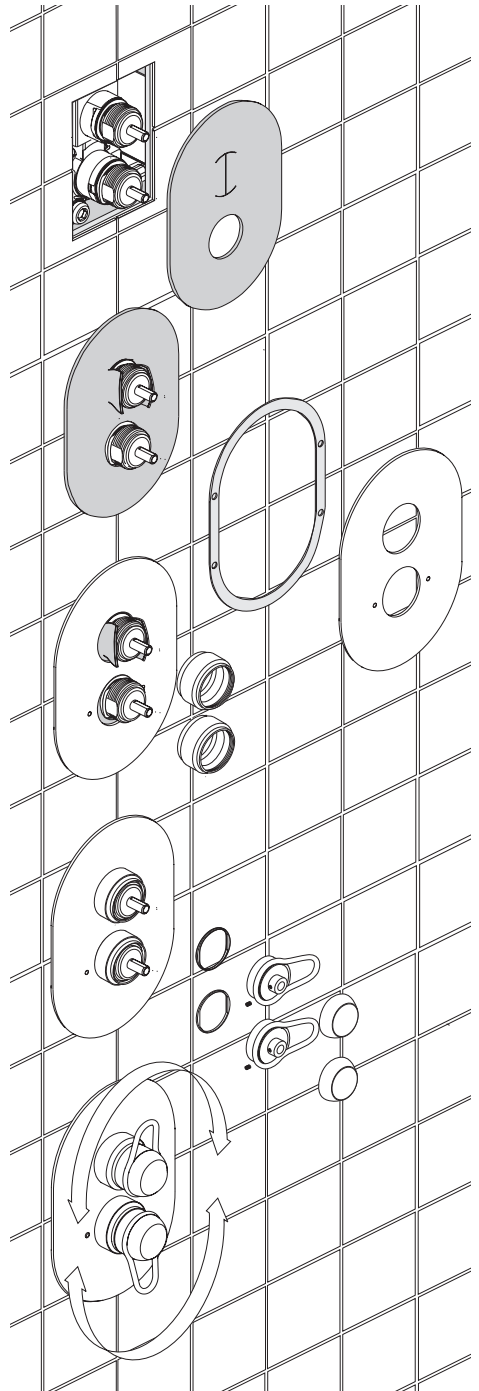

SPARE PARTS

Mira Aquations Spare Parts List

427 32	Checkvalve Assembly
427 33	Filter
427 43	Cartridge Removal Clip
427 48	Seal Pack - components identified 'A'
427 50	Compression Nut and Olive Pack
441 49	Lever Assembly Chrome
441 50	Lever Assembly Gold
441 51	Locknut Assembly
441 52	Concealing Plate
441 53	Concealing Plate Seals
441 54	Spindle
441 55	Headnut
441 56	Flow Cartridge Assembly
441 57	Valve Mounting Bracket
441 58	Screw Pack (not illustrated)
441 59	Wall Mounting Bracket
441 75	Valve Body
1598 030	Thermostatic Cartridge

Mira Aquations Spare Parts Diagram

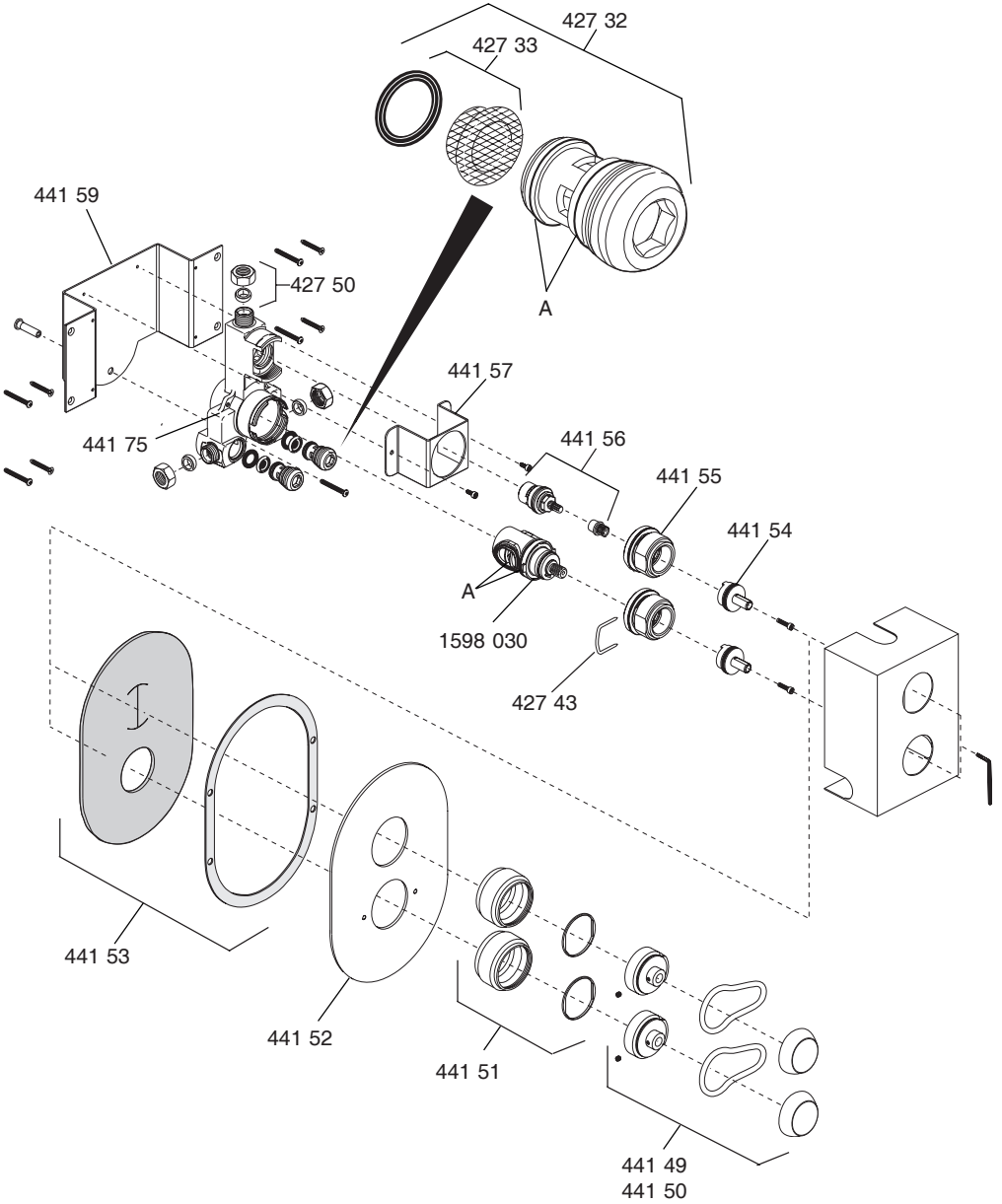

NOTES

NOTES

CUSTOMER SERVICE

Guarantee of Quality

Mira Showers guarantee your product against any defect in materials or workmanship for the period shown in the Guarantee Registration Document included with your shower.

Alternatively, to confirm the applicable guarantee period please contact Customer Services.

To validate the guarantee, please return your completed registration card.

Within the guarantee period we will resolve defects, free of charge, by repairing or replacing parts or modules as we may choose.

To be free of charge, service work must only be undertaken by Mira Showers or our approved agents in Northern Ireland and Republic of Ireland.

Service under this guarantee does not affect the expiry date. The guarantee on any exchanged parts or product ends when the normal product guarantee period expires.

Not covered by this guarantee:

Damage or defects arising from incorrect installation, improper use or lack of maintenance, including build-up of limescale.

Damage or defects if the product is taken apart, repaired or modified by any person not authorised by Mira Showers or our approved agents.

This guarantee is in addition to your statutory and other legal rights.

Before using your shower

Please take the time to read and understand the operating and safety instructions detailed in this manual.

What to do if something goes wrong

If when you first use your shower it doesn't function correctly, first contact your installer to check that installation and commissioning are satisfactory and in accordance with the instructions in this manual. We are on hand to offer you or your installer any advice you may need.

Should this not resolve the difficulty, simply contact our Customer Services who will give every assistance, and if necessary arrange for our service engineer to visit.

If later the performance of your shower declines, consult this manual to see whether simple home maintenance is required. Please call our Customer Services to talk the difficulty through, request service under guarantee if applicable, or take advantage of our comprehensive After-Sales service.

As part of our quality and training programme calls may be recorded or monitored.

Our Customer Services Team is comprehensively trained to provide every assistance you may need: help and advice, spare parts or a service visit.

Spare Parts

We maintain an extensive stock of spares, and aim to have functional parts available for ten years from the date of final manufacture of the product.

Spares can be purchased from approved stockists or merchants (locations on request) or direct from Customer Services.

Spares direct will normally be despatched within two working days. Payment can be made by Visa or MasterCard at the time of ordering. Should payment by cheque be preferred a pro-forma invoice will be sent.

Note! In the interests of safety, spares requiring exposure to mains voltages can only be sent to competent persons.

Service

Our Service Force is available to provide a quality service at a reasonable cost. You will have the assurance of a Mira trained engineer/agent, genuine Mira spares, and a 12 month guarantee on the repair.

Payment should be made directly to the Service Engineer/Agent, using Visa, MasterCard or a cheque supported by a banker's card.

To contact us

England, Scotland & Wales

Mira Showers Customer Services

Telephone: 0870 241 0888

8:30 am to 5:00 pm Working days (4:30 pm Friday)

8:30 am to 12.30 pm Saturday

E-mail: technical@mirashowers.com

Fax: 01242 282595

By Post: Cromwell Road
Cheltenham
Gloucestershire
GL52 5EP

Northern Ireland

Wm H Leech & Son Ltd

Telephone: 028 9044 9257 – Mon to Fri 9 am-5pm

Fax: 028 9044 9234

Post: Maryland Industrial Estate

Ballygowan Road

Moneyreagh, Co Down

BT23 6BL

Republic of Ireland

Modern Plant Ltd

Telephone: 01 4591344 – Mon to Fri 9am to 5pm

Fax: Dublin 01 4592329

Post: Otter House
Naas Road
Clondalkin
Dublin 22

Mira Showers

Kohler Mira Ltd
Cromwell Road,
Cheltenham GL52 5EP.

Mira is a registered trade mark of
Kohler Mira Limited.

The company reserves the right to alter
product specifications without notice.

www.mirashowers.com



FM 14648

mira
SHOWERS